

## TECHNISCHE FICHE

# FS150-1200

**Hoogte** 150mm  
**Breedte** 1200mm

**Brandweerstand** 1 uur (2 uur op bestelling)  
**Milieuklasse** XC1; XC2; XC3 (andere op bestelling)

**Transportgewicht** 2.60 kN/m<sup>2</sup>  
**Gewicht/m** 3.12 kN/m<sup>1</sup>  
**Rekengewicht** 2.70 kN/m<sup>2</sup>  
**Kanaalvulling** 7,56l/m

**Vulbeton** 4.1 l/m<sup>2</sup>  
**Betonkwaliteit** C 50/60  
**Staalkwaliteit** f<sub>pk</sub> 1860; f<sub>p0,1k</sub> 1580

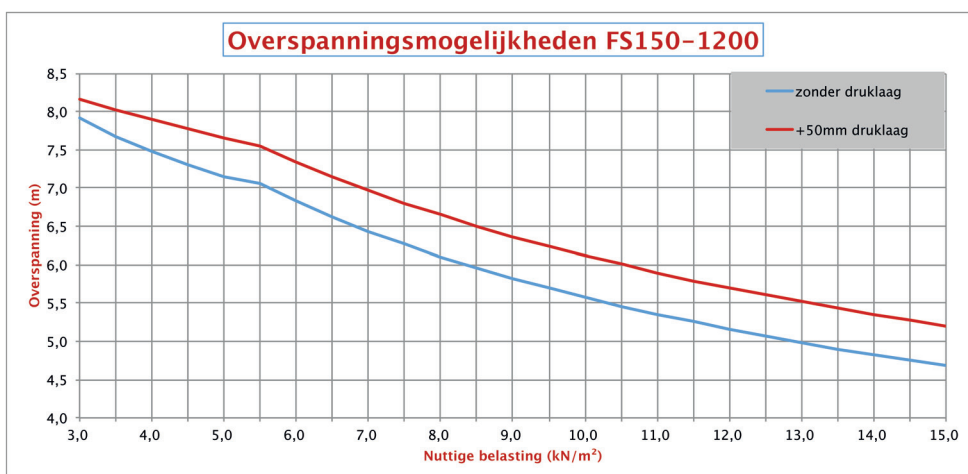
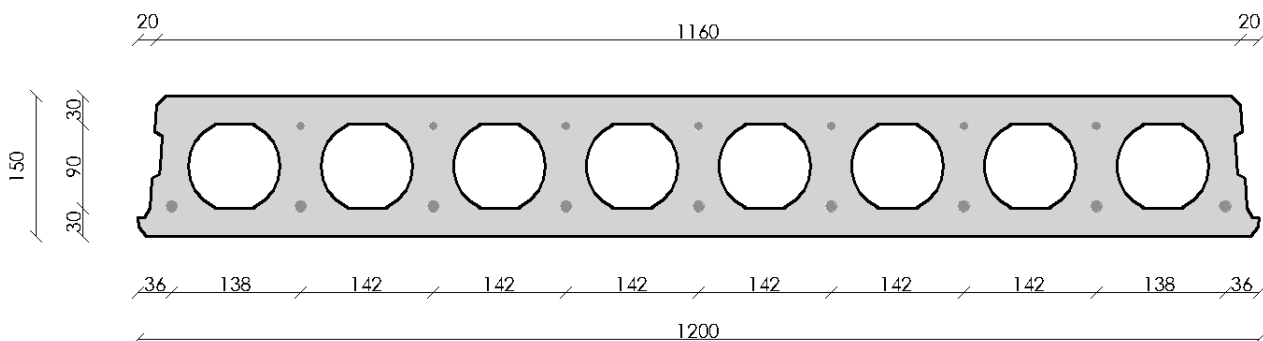

\* overspanningsmogelijkheden gerekend met maximale wapening (geen voorraadelementen)



**BENOR**